



# AMIE™ Precision Studio Monitor



The Amie precision studio monitor is a compact, high-performance loudspeaker designed for critical audio workflows where accurate translation to larger systems is a requirement. Amie traces its lineage to Meyer Sound's Acheron® screen channel loudspeakers, sharing core technology that makes it ideal for film, broadcast, music, and game postproduction.

Amie is equally suited for both stereo and surround monitoring in small- to medium-sized rooms, and is the perfect solution for facilities where the destination is a larger production room. With its flat frequency response, Amie accurately reproduces source material at different listening levels and with its power-to-size ratio can make your edit room sound like the mixing stage.

Sophisticated onboard signal processing and crossover circuitry optimize phase response,

ensuring transparency and precise spatial imaging. When monitoring with Amie, editors and sound designers can trust that their work in the editing suite will successfully translate to the mix stage.

Engineered for sonic linearity, Amie exhibits uniform response over its full dynamic range. Advanced driver protection circuitry allows for graceful handling of peak material with very low distortion, yielding a comfortable listening experience — allowing engineers to work in extended sessions with minimal fatigue.

Amie's high-frequency transducer is a silk-infused dome tweeter fed to a constant directivity waveguide that yields uniform, focused coverage with smooth roll-off outside the coverage area. Its low-frequency transducer is a long-excursion cone driver designed for to behave linear. An optimized,

low turbulence cabinet port enhances power handling and extends low-end response.

Powered by a proprietary 2-channel class D amplifier, Amie boasts ample headroom, low distortion, and low self-noise, delivering consistent performance even at high sound pressure levels, allowing it to reproduce the most demanding soundtracks with uncompromising precision. The self-powered design simplifies room installations. Loop-through power connectors streamline setup of multichannel systems.

Amie's enclosure is constructed from premium birch plywood, coated with an attractive low-gloss, textured black finish. Side attachment points accommodate an optional U-bracket, which can mount on walls and ceilings, or attach to a pole mount. In addition the optional Desk mount allows Amie to be placed on a desk with the ability to tilt.

## FEATURES & BENEFITS

- Seamless translation to larger cinema systems
- Flat frequency and phase response for sonic accuracy
- Uniform tonal balance over a wide dynamic range
- Constant-directivity waveguide yields focused coverage
- Handles high SPL and peaks with very low distortion
- Self-powered for simplified setup and increased reliability
- Individually tested for consistent performance

## SOLUTIONS

- Small- to medium-sized editing rooms
- Stereo and surround mixing for film and video postproduction
- Broadcast monitoring
- Music editing and mixing
- High-end playback systems

## AMIE SPECIFICATIONS

### ACOUSTICAL

|                              |                             |
|------------------------------|-----------------------------|
| Frequency Range <sup>1</sup> | 45 Hz – 20 kHz              |
| Phase Response               | 350 Hz – 20 kHz ±30 degrees |

### COVERAGE

|            |            |
|------------|------------|
| Horizontal | 80 degrees |
| Vertical   | 50 degrees |

### CROSSOVER<sup>2</sup>

1500 Hz

### TRANSDUCERS

|                |   |
|----------------|---|
| Low Frequency  | One 6.5-inch long-excursion cone driver                     |
| High Frequency | One 1-inch dome tweeter on a constant-directivity waveguide |

### AUDIO I/O

|                           |   |
|---------------------------|---|
| Connectors                | XLR 3-pin female input with XLR 3-pin male loop output  |
| Nominal Input Sensitivity | 6.0 dBV (2.0 V rms, 2.8 V peak) continuous is typically the onset of limiting for noise and music |

### AMPLIFIER

|      |   |
|------|---|
| Type | Class D, 2-channels with electronic crossover |
|------|---|

### AC POWER

|                              |   |
|------------------------------|---|
| Connectors                   | powerCON 20 with loop output out (up to 7 Amie Loudspeakers can be safely looped) |
| Safety Rated Voltage Range   | 100–240 V AC, 50–60 Hz  |
| Turn-on/off Points           | 90 V AC turn-on, no turn-off; internal fuse protection above 265 V AC             |
| Max. Long-Term Cont. Current | 0.65 A rms (115 V AC); 0.35 A rms (230 V AC); 0.77 A rms (100 V AC)               |

### PHYSICAL

|            |   |
|------------|---|
| Dimensions | 9.00 inches W x 15.30 inches H x 13.24 inches D<br>(229 mm x 389 mm x 336 mm) |
| Weight     | 25 lbs (11.3 kg)  |
| Enclosure  | Premium birch plywood with low-gloss, textured black finish                   |
| Mounting   | 3/8"–16 threaded side attachment points; for optional mounting accessories    |

### NOTES

1. Free field, measured with 1/3-octave frequency resolution at 1 meter.
2. At this frequency, the transducers produce equal sound pressure levels.

Amie  
04.249.004.02 A

Copyright © 2016  
Meyer Sound Laboratories Inc.  
All rights reserved

**MEYER SOUND LABORATORIES INC.**  
2832 San Pablo Avenue  
Berkeley, CA 94702

+1 510 486.1166

techsupport@meyersound.com  
www.meyersound.com

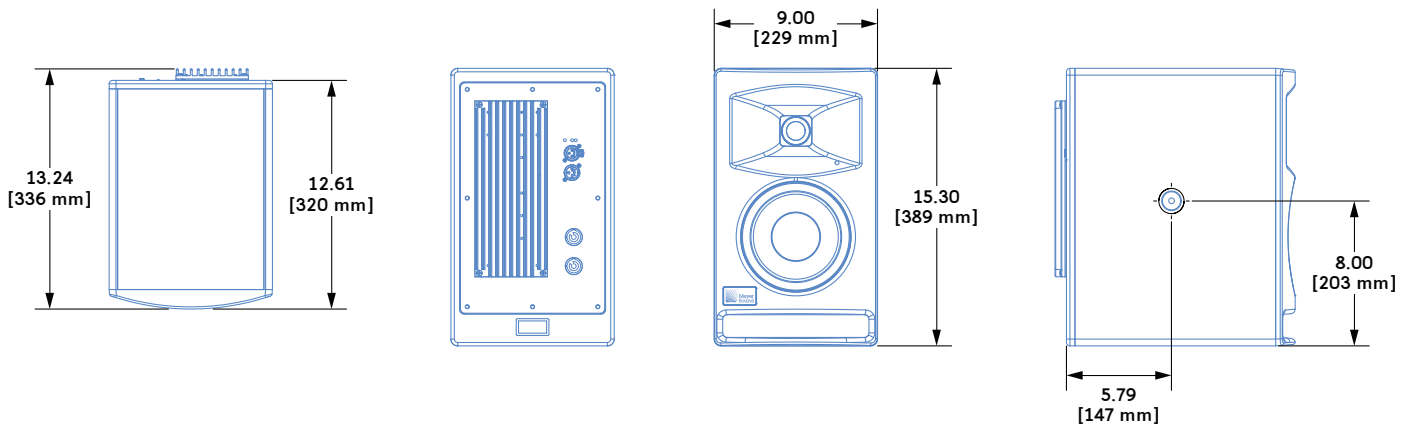

## MOUNTING OPTIONS

Mounting options include the Amie Desktop Stand (40.249.086.01) and the standard Amie MUB Kit (40.249.061.01), which can be attached to stands or suspended from the ceiling.

## ARCHITECT SPECIFICATIONS

The loudspeaker shall be a self-powered studio monitor. Its transducers shall include one 6.5-inch diameter long-excursion cone driver and one 1-inch dome tweeter on a constant-directivity waveguide.

The loudspeaker shall incorporate internal processing and a 2-channel class D amplifier, one channel for each driver. Processing shall include equalization, phase correction, driver protection, and signal division.

Performance specifications for a typical production unit shall be as follows, measured at 1/3-octave resolution: frequency range, 45 Hz to 20 kHz; phase response, 350 Hz to 20 kHz ± 30 degrees.

Horizontal coverage shall be 80 degrees and vertical coverage shall be 50 degrees. The crossover point shall be 1500 Hz.

Audio connectors shall be XLR 3-pin, female and male, accommodating balanced audio. The audio input shall accept a nominal 6 dBV (2.0 V rms, 2.8 V peak) signal.

The internal power supply shall perform automatic voltage selection, EMI filtering, soft current turn-on, and surge suppression. Power requirements shall be nominal 100, 110, or 230 V AC line current at 50–60 Hz. UL and CE operating voltage range shall be 100–240 V AC at 50–60 Hz. AC power connectors for input and

loop output shall be powerCON 20. Maximum long-term continuous current draw shall be 0.65 A rms at 115 V AC, 0.35 A rms at 230 V AC and 0.77 A rms at 100 V AC.

Components shall be mounted in an optimally tuned, vented enclosure constructed of premium birch plywood with a low-gloss, textured black finish.

Dimensions shall be 9.00 inches wide x 15.30 inches high x 13.24 inches deep (229 mm x 389 mm x 336 mm). Weight shall be 25 lbs (11.3 kg).

The loudspeaker shall be the Meyer Sound Amie.